

BY Series

Small emitter/receiver synchronizing type

■ Features

- Small size : W12×H16×D30mm
- Minimizing malfunction by extraneous light by synchronizing emitter and receiver.
- Reverse power polarity and overcurrent
- Fast response speed : Max. 1ms



⚠ Please read "Caution for your safety" in operation manual before using.

■ Specifications

Model	Standard type	Side sensing type
	BY500-TDT	BYS500-TDT
Sensing type	Transmitted beam	
Sensing distance	500mm	
Sensing target	Opaque materials of Min. ϕ 5mm	
Response time	Max. 1ms	
Power supply□	12-24VDC \pm 10% (Ripple P-P : Max. 10%)	
Current consumption	Max. 30mA	
Light source	Infrared LED(modulated)	
Operation mode	Dark ON	
Control output	NPN open collector output \Rightarrow Load voltage : 30VDC, Load current : Max. 100mA, Residual voltage : Max. 1V	
Protection circuit	Reverse polarity protection, Short-circuit protection	
Indicator	Operation indicator : Red LED	
Connection	Outgoing cable(2m)	
Insulation resistance	Min. 20M Ω (at 500VDC mega)	
Noise strength	\pm 240V the square wave noise (pulse width:1 μ s) by the noise simulator	
Dielectric strength	1,000VAC 50/60Hz for 1minute	
Vibration	1.5mm amplitude at frequency of 10 ~ 55Hz in each of X, Y, Z directions for 2 hours	
Shock	500m/s ² (50G) in X, Y, Z directions for 3 times	
Ambient illumination	Sunlight : Max. 11,000 lx, Incandescent lamp : Max. 3,000 lx	
Ambient temperature	-10 ~ +60 $^{\circ}$ C (at non-freezing status), Storage : -25 ~ +70 $^{\circ}$ C	
Ambient humidity	35 ~ 85%RH, Storage : 35 ~ 85%RH	
Protection	IP50(IEC standard)	
Material□	Case : ABS, Lens : Acrylic□	
Cable	4P, ϕ 4mm, Length : 2m	
Accessory	Fixing bracket, Bolts/Nuts	
Unit weight	Approx. 150g	

Small and Amplifier Built-in Type

Feature data

●BY500-TDT ●BYS500-TDT

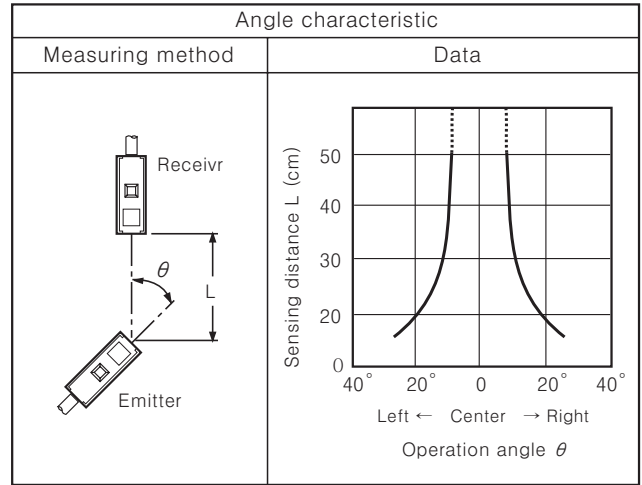
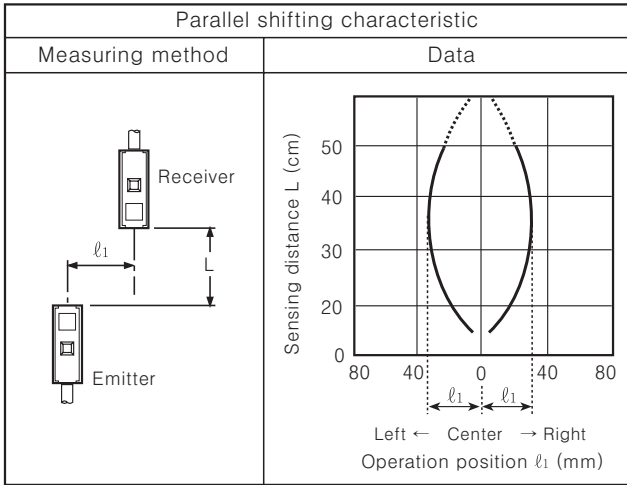

Control output diagram

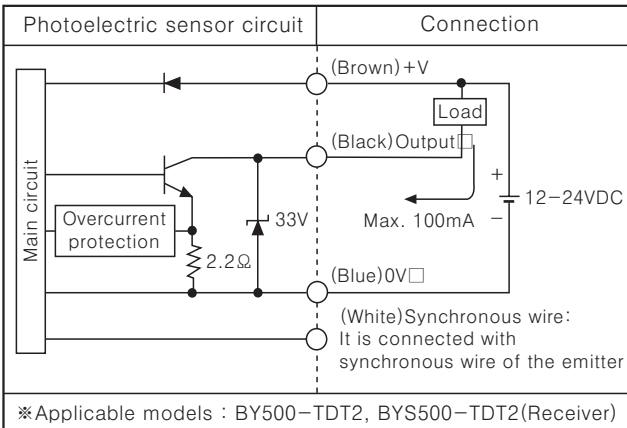

- ※ If the control output terminal is short-circuited or overcurrent condition is existed, the control output will turn off due to protection circuit.
- ※ Please supply the power to Brown and Blue wire of emitter and Synchronous wire(White) of the receiver must be connected with that of the emitter.

Operation mode

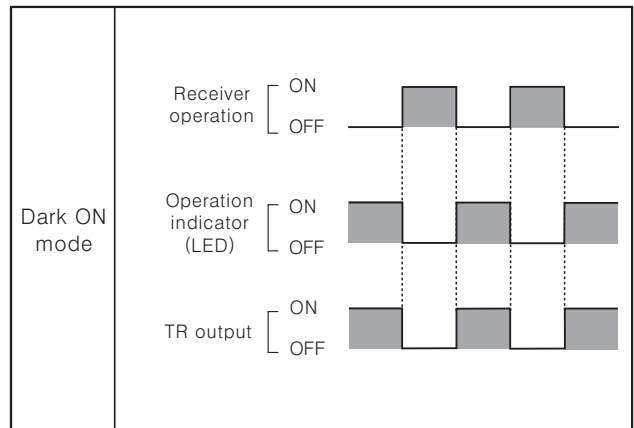

Connections

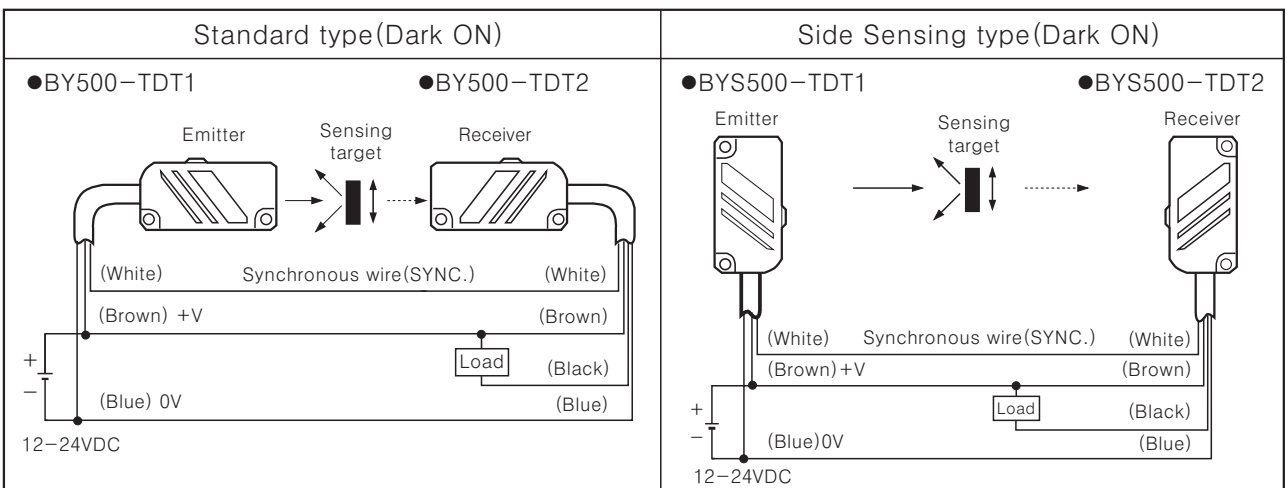

- ※ The power of the emitter and the receiver must be supplied from same power line.
- ※ Synchronous wire(White) of the receiver must be connected with that of the emitter.

(A) Counter

(B) Timer

(C) Temp. controller

(D) Power controller

(E) Panel meter

(F) Tacho/Speed/Pulse meter

(G) Display unit

(H) Sensor controller

(I) Switching power supply

(J) Proximity sensor

(K) Photo electric sensor

(L) Pressure sensor

(M) Rotary encoder

(N) Stepping motor & Driver & Controller

(O) Graphic panel

(P) Production stoppage models & replacement

BY Series

■ Dimensions

(Unit:mm)

●Product(BY500-TDT)

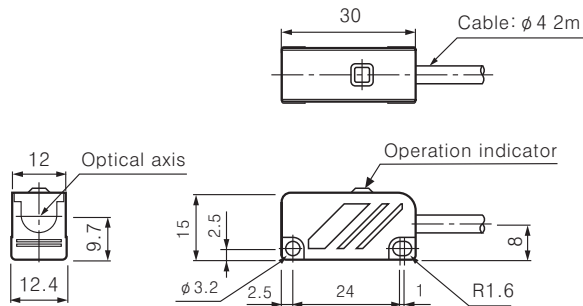

●Product(BYS500-TDT)

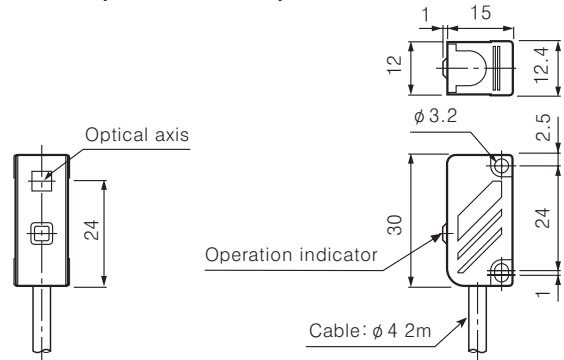

●Bracket(BY500-TDT)

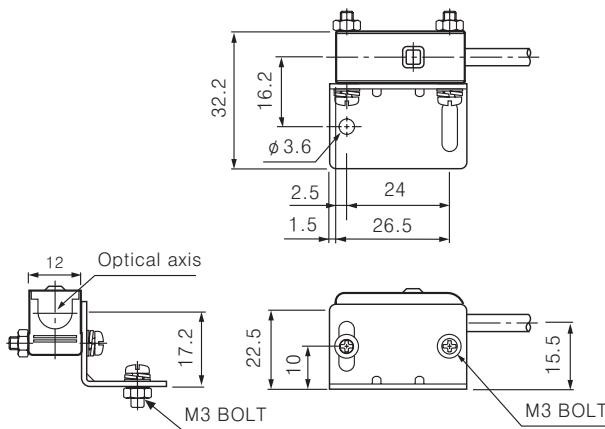

●Bracket(BYS500-TDT)

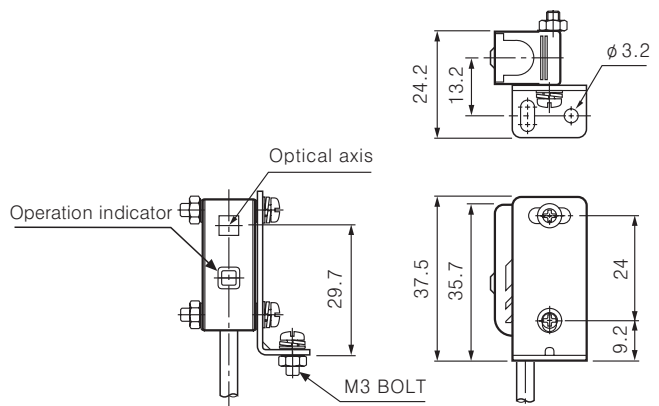

●Bracket(BY500-TDT)

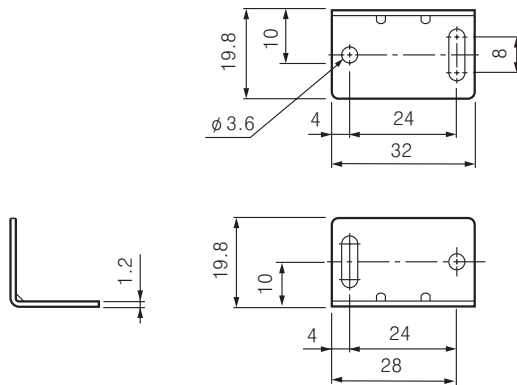

●Bracket(BYS500-TDT)

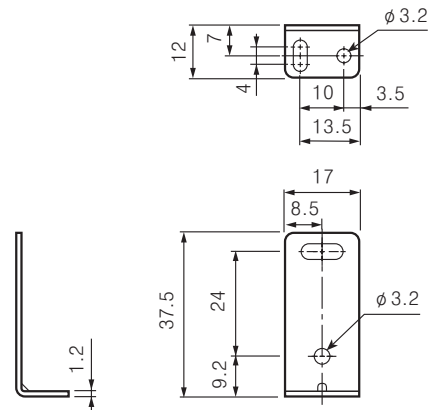

■ Mounting and sensitivity adjustment

1. Supply the power to the sensor, after install the emitter and the receiver facing each other.
2. Set the receiver in the middle of position where indicator turns on adjusting the receiver to the right and the left or up and down.
3. Fix both units tightly after checking that the unit detect the target.

※If the sensing target is translucent body or smaller than $\phi 5\text{mm}$, it might not be detected because the target allows too much light to pass.

